

### Safety Warning



- The installation should be carried out by a qualified electrician in compliance with the current edition of the IEE Wiring Regulations.
- Prior to installation, carry out the necessary risk assessment considering the people who could be at risk, the level of risk and the precautions required to control the risk
- Ensure that the circuit supply is isolated either by the circuit supply fuse being removed or the applicable circuit breaker being turned off before installation or any maintenance.
- Check the total load on the circuit ensuring the luminaire does not exceed the rating of the circuit cable, fuse or circuit breaker.
- Long-term use and voltage fluctuations can reduce the life span of the fitting.
- If the fitting incorporates control gear, ensure careful sizing to avoid instances of nuisance tripping of the protective device used in the installation.
- Follow the provided installation instructions, using the fixings supplied or recommended.
- Keep out of reach of children.



### Specification

**Box Contents -**  
1 x Discus Pro Smart Downlight with Wifi BLE USB

<b>Dimensions:</b>	Ø: 540 x D: 44mm
<b>Material:</b>	Body: PC & Aluminium Diffuser: PS
<b>Working Temperature:</b>	-20°C - 40°C
<b>Included:</b>	Fast fit Terminal Block Wifi BLE USB

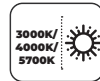
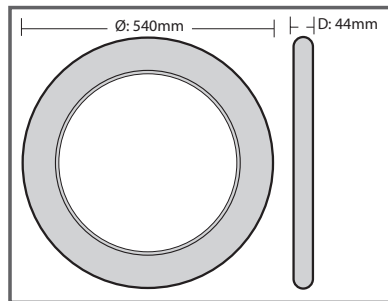

### MAXIMUM FITTINGS PER CIRCUIT

Automatic Circuit Breaker Type:	B6	B10	B13	B16	B20	C10	C13	C16	C20
<b>Rated Current:</b>	6A	10A	13A	16A	20A	10A	13A	16A	20A
<b>Cable (mm):</b>	1.5	1.5	1.5	1.5	2.5	1.5	1.5	1.5	2.5
<b>DSP50-SWB</b>	20	31	31	31	51	31	31	31	51

### Installation Instructions - Surface Mounted

1. Rotate counterclockwise to remove the bracket.

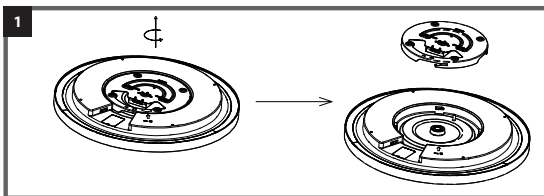

2. Remove the terminal cover and mark the mounting hole.

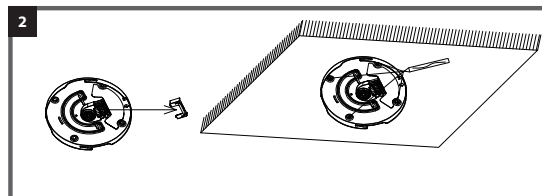

3. According to the mounting bracket, confirm the mounting position and fix it with screws

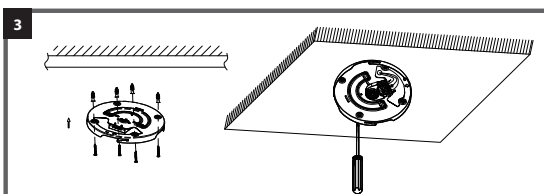

4. Power off first, then connect the wire L/N/GND to the terminal, and fix the terminal cover.

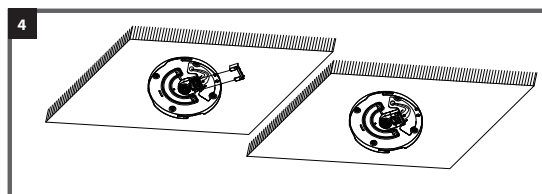

5. Aim the raised section of the lamp at the mounting port of the bracket and apply force upward. At the same time, turn the lamp into the bracket clockwise.

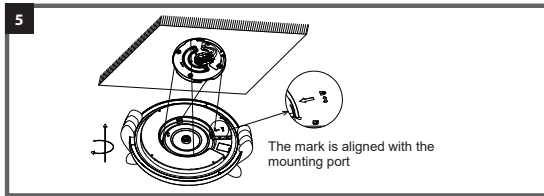

6. The installation is now complete.

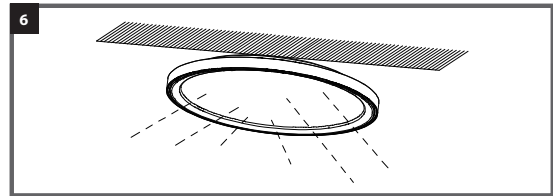

### Installation Instructions - Suspension Mounted

1. Rotate counterclockwise to remove the bracket.

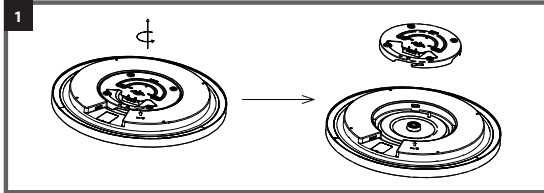

2. Remove the terminal cover and mark the mounting hole.

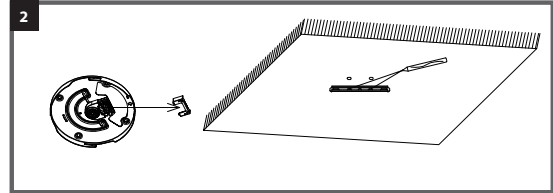

3. According to the mounting bracket, confirm the mounting position and fix it with screws.

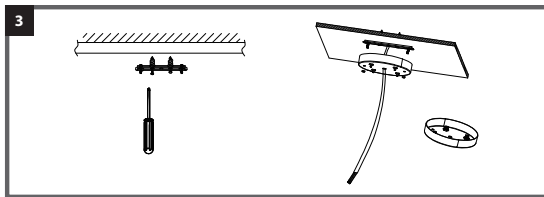

4. Fix 4 lifting screws & fix 4 hanging ropes.

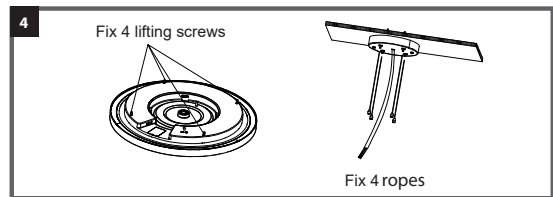

5. First, fix the lamp to the lifting rope, and then connect the L/GND/N line to the corresponding L/GND/N in the terminal at the same time, turn the lamp into the bracket clockwise.

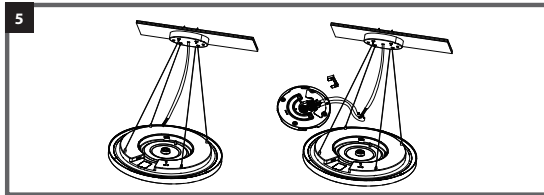

6. Install the bracket clockwise on the lamp, confirm stability, installation is now complete.

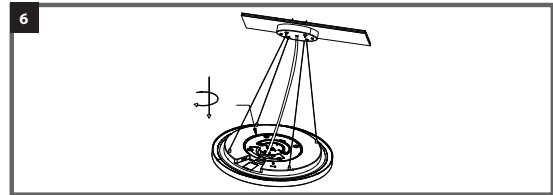

### Wifi/BLE Installation

**(Note: NOT essential, the luminaire will still work as a standard CCT changeable luminaire without the Wifi/BLE USB connection)**

1. Check the USB stick has Wifi function.
2. Insert the USB.

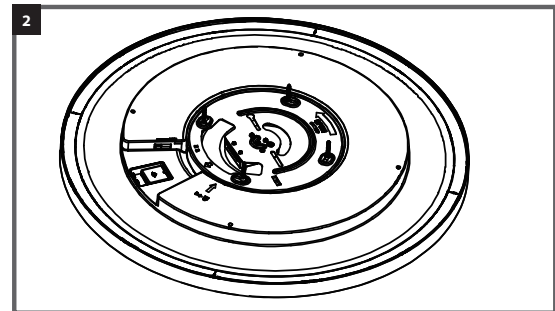
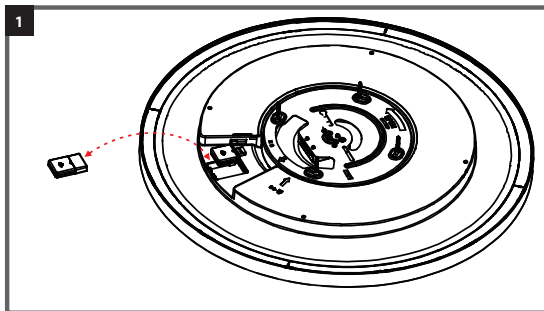

3. Ensure the USB cover is securely fastened.
4. While the USB stick is inserted into the luminaire, it will be detected and the luminaire will switch to App control mode automatically. If you take the USB stick out, the luminaire is just a normal CCT changeable light.

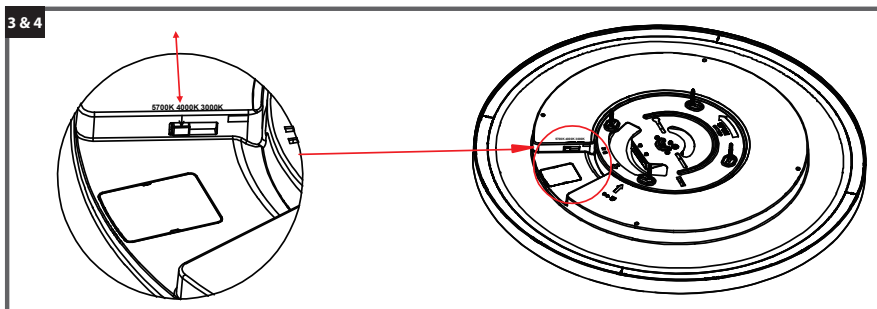

## Tuya Dual Mode Wifi / BLE App Instructions

1. Install the Tuya App on your smartphone.
2. Check the Wifi connection is good, ensure your smartphone is connected to the Wifi and Bluetooth connection is switched on.
3. Tap the Tuya App to get started and register an account.
4. Resetting the device to enable pairing with smartphone:
  - Switch on the power to the light.
  - Follow the steps below to turn the switch ON/OFF 3 times. You will need to wait 3-4 seconds while it is turned OFF before turning on again. When the light flashes quickly, it means you are entering the reset code step.

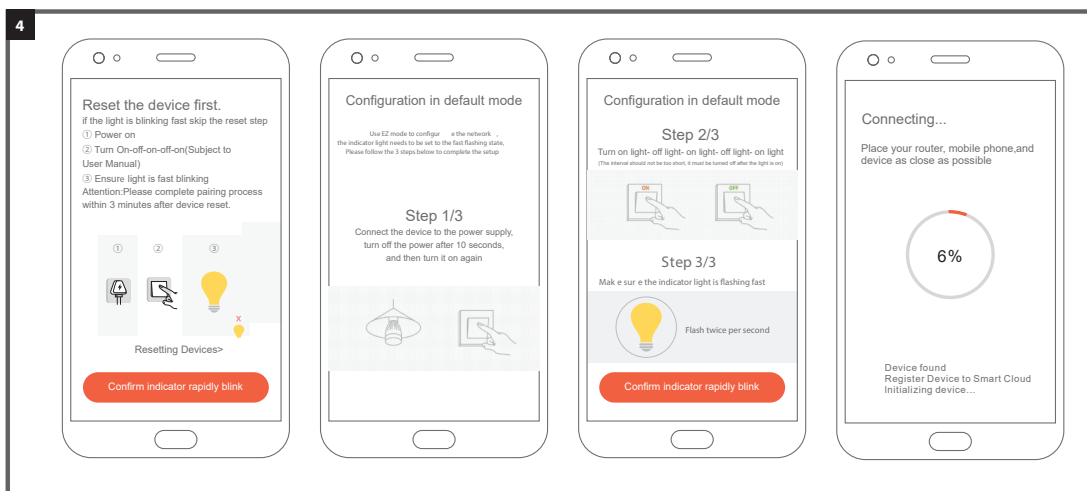

5. After following the steps above, select the Wifi network name and connect to it, in the meantime, the light should still be flashing quickly, it will stop flashing once the luminaire is found on the App. When the progress bar reaches 100% the connection is successful.
6. Now enter the app to operate dimming or CCT change functions.
7. When the App is updated, please reconnect with the steps in the App.
8. BLE verification: unplug the Wifi connection router, and then switch the mobile 3/4/5G off. The Tuya App should still control the luminaire, meaning the Bluetooth control is working.

## Guarantee

This product is guaranteed for a period of 5 years from the date of purchase. The guarantee is invalid in the case of improper use, tampering, removal of the Q.C. date label, installation in an improper working environment or installation not according to the current edition of the I.E.E. Wiring Regulations (BS7671). The guarantee is also invalidated if the luminaire has been insulation tested. Should this product fail during the guarantee period it will be replaced free of charge, subject to correct installation and return of the faulty unit. We do not accept responsibility for any installation costs associated with the replacement of this product. Your statutory rights are not affected. We reserve the right to alter specifications without prior notice.

## Maintenance

- This fitting will require routine cleaning if used in adverse (dust, paint, welding, oils etc) environments. Do not use solvents, aggressive detergents or abrasives.
- The light source & driver in this luminaire are non-replaceable.

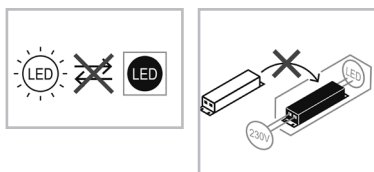

- When this fitting comes to the end of its life or you choose to replace it, please do not dispose of it with your normal waste. Please recycle where the facilities exist, check with your local authority for suitable options.

INS/COMMERCIAL/0013/DSP/V2