



JUNCTION BOX



Suitable for use with 5A, 15A & 30A connector strips (not supplied) and is complete with lid fixing and cord grip screws.

Features

- 17th Edition compliant
- Flame retardant
- Supplied with screws and cable grips

Specification

Material:	Flame Retardent Polymer
Colour Finish:	White
Guarantee:	10 Year

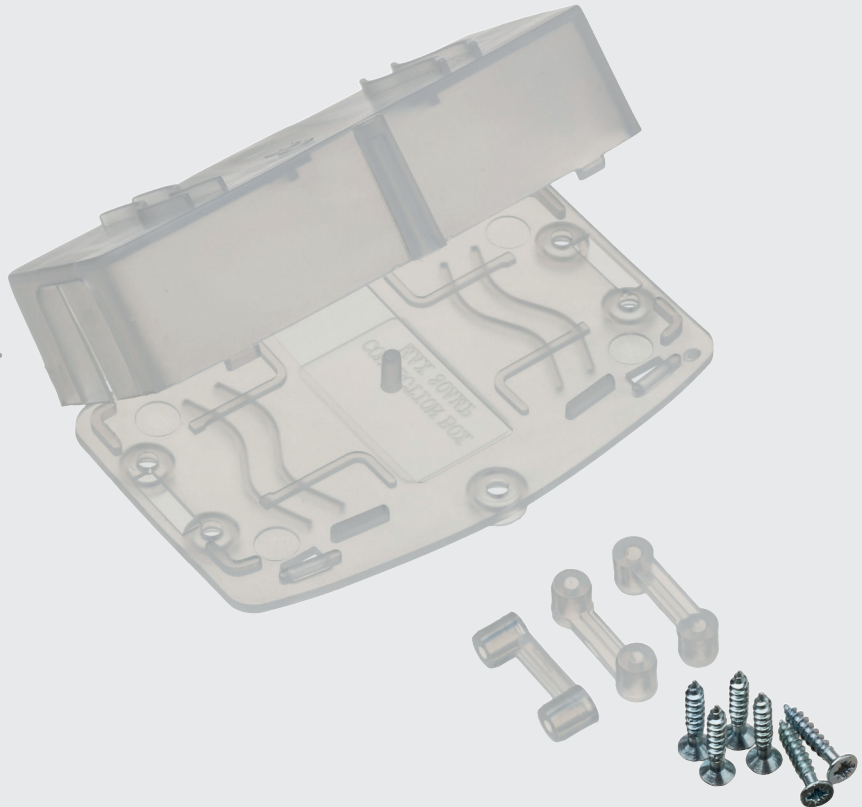

Product Code	Description	Amp	Dimensions	Weight (Kg)	Barcode
TFBX	Junction Box	5-30A	L: 91 x W: 56 x D: 26mm	0.04	5055807611114



www.redarrowelectrical.co.uk