

### Safety Warning



- The installation should be carried out by a qualified electrician in compliance with the current edition of the IEE Wiring Regulations.
- Prior to installation, carry out the necessary risk assessment considering the people who could be at risk, the level of risk and the precautions required to control the risk
- Ensure that the circuit supply is isolated either by the circuit supply fuse being removed or the applicable circuit breaker being turned off before installation or any maintenance.
- Check the total load on the circuit ensuring the luminaire does not exceed the rating of the circuit cable, fuse or circuit breaker.
- Long-term use and voltage fluctuations can reduce the life span of the fitting.
- If the fitting incorporates control gear, ensure careful sizing to avoid instances of nuisance tripping of the protective device used in the installation.
- Follow the provided installation instructions, using the fixings supplied or recommended.
- Keep out of reach of children.



### Specification

**Box Contents -**  
1 x LED Lamp, 1x Stand & Screws

<b>Dimensions:</b>	L: 270 x W: 200 x D: 160mm
<b>Material:</b>	ABS Body & Glass Lens
<b>Working Temperature:</b>	Standard: -20°C - 50°C
<b>Included:</b>	1.8m Cable

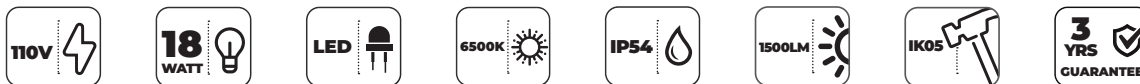
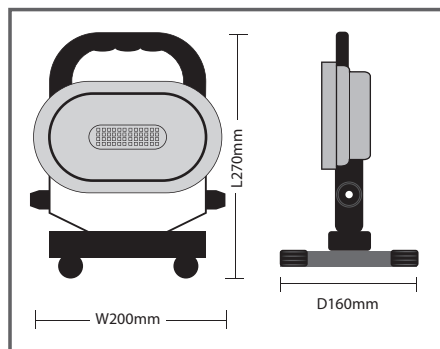

### Installation Instructions

- Remove all contents from the box.
- Place the lamp body on top of the stand and insert the provided screw from the top and fully tighten.
- Connect the 110V plug to the nearest power supply / transformer and make sure the fitting works correctly.

### Guarantee

This product is guaranteed for a period of 3 years from the date of purchase. The guarantee is invalid in the case of improper use, tampering, removal of the Q.C. date label, installation in an improper working environment or installation not according to the current edition of the I.E.E. Wiring Regulations (BS7671). The guarantee is also invalidated if the luminaire has been insulation tested. Should this product fail during the guarantee period it will be replaced free of charge, subject to correct installation and return of the faulty unit. We do not accept responsibility for any installation costs associated with the replacement of this product. Your statutory rights are not affected. We reserve the right to alter specifications without prior notice.

### Maintenance

- This fitting will require routine cleaning if used in adverse (dust, paint, welding, oils etc) environments. Do not use solvents, aggressive detergents or abrasives.
- The light source & driver in this luminaire can not be replaced. When this fitting comes to the end of it's life or you choose to replace it, please do not dispose of it with your normal waste. Please recycle where the facilities exist, check with your local authority for suitable options.

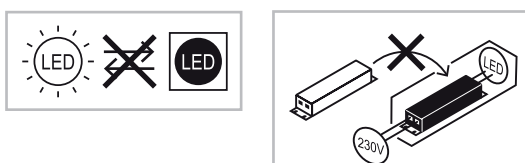

INS/SITE/0012/GLH18/V2