

INSTALLATION INSTRUCTIONS

Vanguard Maxi M/NM Bulkhead 1500lm 3Hr IP65 Selectable Self/Manual Test
 Product Codes: **VANMX/15/ST/V3**

Safety Warning



- The installation should be carried out by a qualified electrician in compliance with the current edition of the IEE Wiring Regulations.
- Prior to installation, carry out the necessary risk assessment considering the people who could be at risk, the level of risk and the precautions required to control the risk
- Ensure that the circuit supply is isolated either by the circuit supply fuse being removed or the applicable circuit breaker being turned off before installation or any maintenance.
- Check the total load on the circuit ensuring the luminaire does not exceed the rating of the circuit cable, fuse or circuit breaker.
- Long-term use and voltage fluctuations can reduce the life span of the fitting.
- If the fitting incorporates control gear, ensure careful sizing to avoid instances of nuisance tripping of the protective device used in the installation.
- Follow the provided installation instructions, using the fixings supplied or recommended.
- Keep out of reach of children.



Specification

Box Contents -
 1 x Maintained / Non-Maintained 230V Emergency Bulkhead Selectable Self Test / Manual Test Functionality

Dimensions:	L: 321 x W: 167 x D: 83mm
Material:	Body: ABS Lens: Polycarbonate
Colour Temperature:	6500K
LED Lifetime:	54,000 Hrs
IP Rating:	IP66
IK Rating:	IK08
Working Temperature:	0°C to 45°C
Warranty:	5 Years

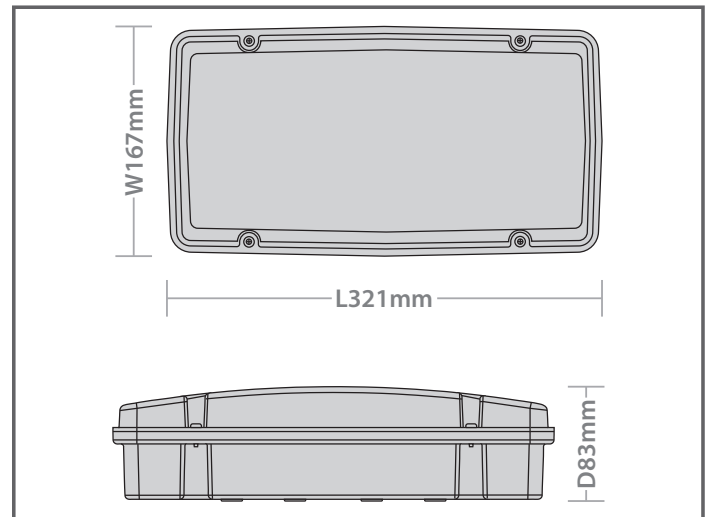

Installation Instructions

1. Isolate the mains supply before carrying out any installation or maintenance work.
2. Remove the diffuser/lens from the fitting by loosening the 4 x screws. Release the safety cord
3. Drill out the preferred fixing points and cable entry point. There are cable entries on the back and at either end of the body. Fix the body in the body in the desired location, passing the supply cable through the cable entry point. Ensure that a suitable cable gland is used to maintain the IP66 rating.

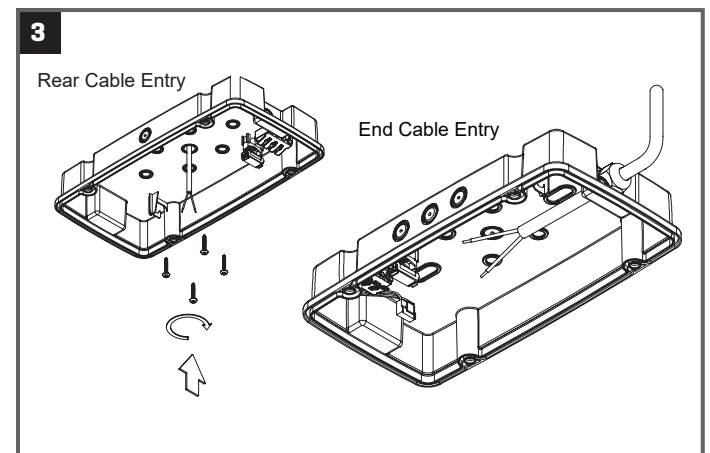
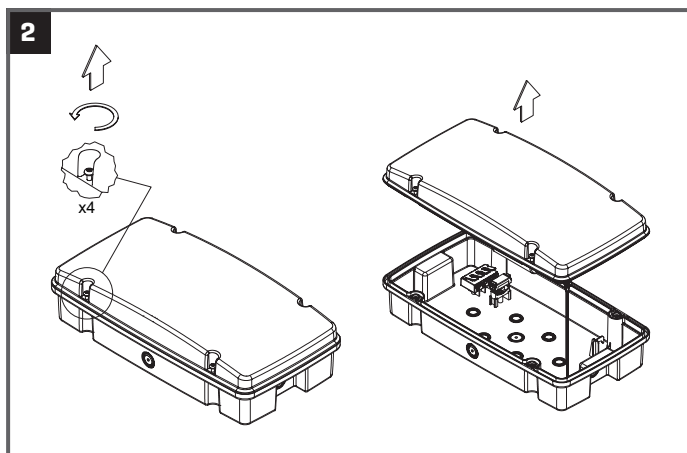

- Connect the supply cable to the terminal block. An unswitched supply must be connected to the Live (L) and Neutral (N) terminals. Use the fitted cable strain relief clamp. For non-maintained version remove link between LS and L
- Reconnect the safety cord between the gear tray/diffuser and the body. Plug the lead from the battery into the white 3 pin connector on the PCB. Plug the power lead from the terminal block onto the power connection on the PCB.

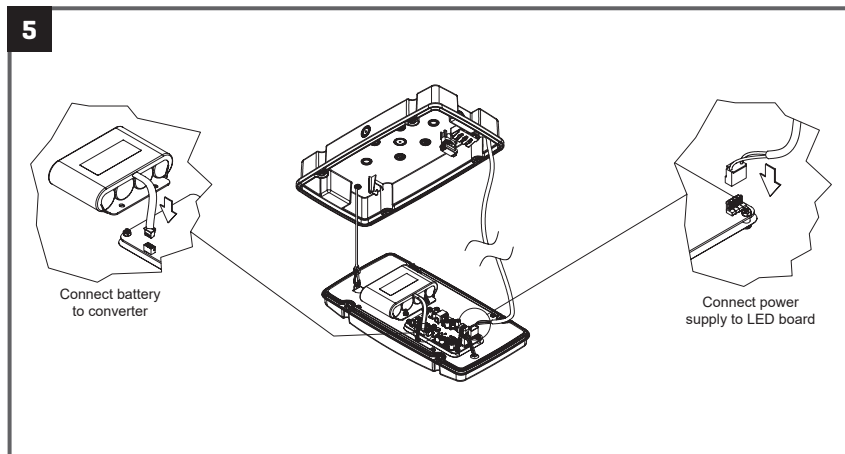
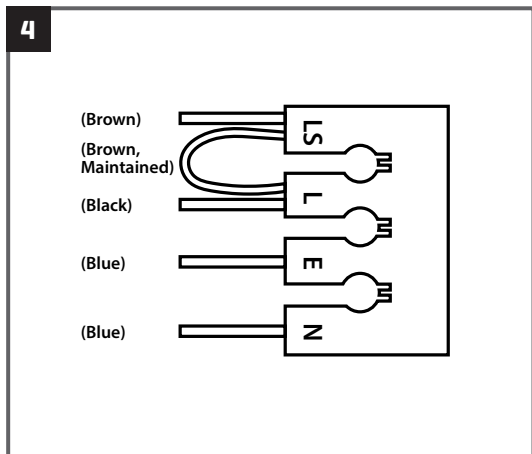

- This fitting has adjustable lumen output of 1000 lm or 1500 lm, as standard this will be set to 1500lm (H) if 1000lm is required set the switch to (L).
- Select the desired function, as standard this will be set to self test operation (EL-T) if manual test operation is required set the switch to manual test operation (EL)
- Replace the diffuser/lens, making sure all four screws are fully tightened to ensure a good seal.
- Restore the mains supply and check that the green LED indicator is illuminated and that the luminaire operates correctly.
- Leave the power connected for 24 hours to fully charge the batteries and then carry out an emergency commissioning test.

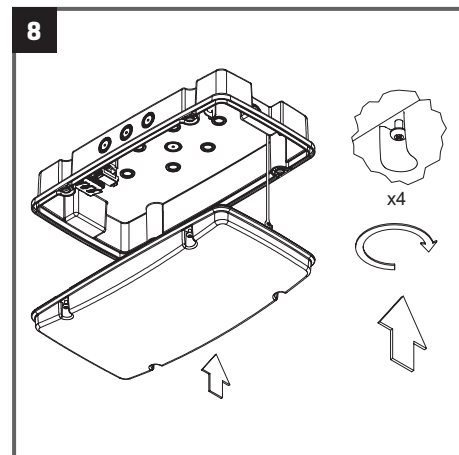
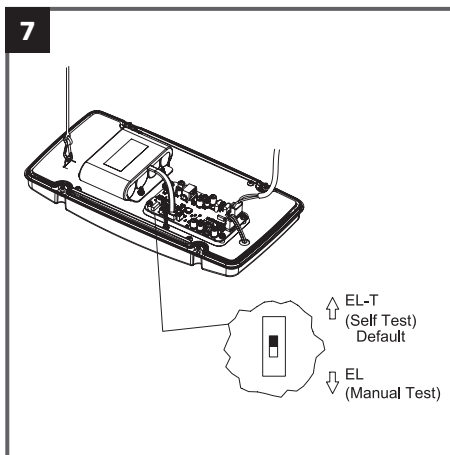
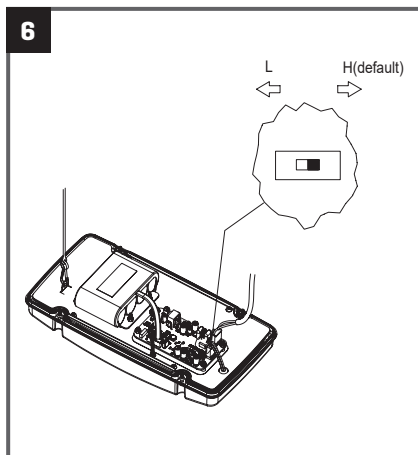

Self Test Operation

VANMX/15/ST/V2 will be supplied preset to EL-T for stand alone automatic self test operation.

After the power supply has been connected and the batteries have charged for 24 hours, the fitting will perform the following tests automatically, which meet and exceed legal requirements. The status during and after the tests is provided by a bi-colour LED Indicator

Initial Duration Test

This is carried out 24 hours after the fitting has been connected to the power supply, provided the supply is uninterrupted and the batteries have been charging for this period. This test lasts for the rated duration of the luminaire, 3 hours.

Function Test

This test is carried out every week for 5 seconds, checking the functionality of the emergency module, batteries and LED module.

Duration Test

This is carried out every half year, on one day within the 175th day to the 195th day. The test lasts for the rated duration of the luminaire, 3 hours.

NOTES:









The timing function is accurate to within $\pm 75s$ per week. Timing is retained during periods of mains failure or interruption for up to 7 days.

Tests will not be performed when the mains supply is disconnected

When there is a lamp failure at non-maintained mode, the indicator remains green but will turn red and be slow flashing after the failure is detected in a weekly function test.

System Status Indication

The system status, including testing and any faults is provided by a bi-colour LED indicator on the fitting. Status is provided as follows:

LED Colour	Status	Flash Rate On Time	Flash Rate Off Time	Details	
Green		Permanent On	-	-	Normal operation - Battery is charging
		Slow Flash	1s	1s	3 hr duration test in progress
		Fast Flash	0.2s	0.2s	5s function test in progress
		Flash 3 Times only	0.5s	0.5s	Self test timer reset
Red		Permanent On	-	-	Battery charge failure
		Slow Flash	1s	1s	LED module failure
		Fast Flash	0.2s	0.2s	Battery duration failure
Off		Off	-	-	System in emergency mode. Mains disconnected from battery, or mains failure

Test Button

The fitting has a test button, which can be used to perform the following functions:

Press for < 2s – Simulate emergency mode

Press for 3-5s – Manually start a duration test. Abort test by pressing the button for 1-2s

Press for 5-8s – Manually start a 60s function test. Abort test by pressing the button for 1-2s

Press for > 10s – Timer reset

Battery Replacement

1. Isolate the mains supply and remove the front cover.
2. Unplug the battery lead from the circuit board.
3. Write the current date on the new battery pack.
4. Fit the new battery pack.
5. Plug the battery back into the circuit board.
6. Replace the front cover, restore the power and allow to charge for 24 hours. Then carry out a full duration test.
7. After restoring the power press the test button for >10s to reset the timer and allow to charge for 24 hours.
8. The fitting will carry out an automatic duration test after 24 hours. Check the indicator status after the test for normal operation

Warranty

This product is guaranteed for a period of 5 years from the date of purchase. The warranty is invalid in the case of improper use, tampering, removal of the Q.C. date label, installation in an improper working environment or installation not according to the current edition of the I.E.E. Wiring Regulations (BS7671). The warranty is also invalidated if the luminaire has been insulation tested. Should this product fail during the warranty period it will be replaced free of charge, subject to correct installation and return of the faulty unit. We do not accept responsibility for any installation costs associated with the replacement of this product. Your statutory rights are not affected. We reserve the right to alter specifications without prior notice.

Maintenance

- This fitting will require routine cleaning if used in adverse (dust, paint, welding, oils etc) environments. Do not use solvents, aggressive detergents or abrasives.
- The light source & driver in this luminaire can be quickly and easily replaced at end of life. This should be carried out by a competent person. Contact Red Arrow for details of replacements.

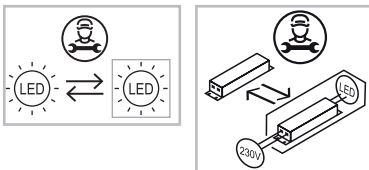

- When this fitting comes to the end of its life or you choose to replace it, please do not dispose of it with your normal waste. Please recycle where the facilities exist, check with your local authority for suitable options.

VANNMX_ST_V3



INSTALLATION INSTRUCTIONS

Emergency Testing Sheet

Testing (Emergency Versions)

The emergency lighting must be tested and inspected regularly in accordance with local codes of practice.

NOTE: For safety reasons tests should be carried out preceeding time of low risk, to allow for battery recharge.

The minimum recommended test schedule is as follows:

Commissioning - After installation, allow 24 hours to ensure full battery charge, and then interrupt the supply; check after 3 hours that the light is still illuminated.

1. Daily - Check that the charge indicator LED is working.
2. Monthly - Interrupt the power supply for a period sufficient to ensure each light is illuminated. At the end of the test, restore the supply and check the indicator is illuminated.
3. Annually - Interrupt the supply as in 2, but for the full rated duration. Ensure the light is illuminated at the end of the rated duration. Restore the supply and check the indicator is illuminated.
4. Record the date and result of each test, attending to any maintenance required in the event of a test failure.

Luminaire Location

Date Installed

Date Commisioned

Month	Test	Year 1			Year 2			Year 3		
		Signed	Result / Action	Date	Signed	Result / Action	Date	Signed	Result / Action	Date
1	Functional									
2	Functional									
3	Functional									
4	Functional									
5	Functional									
6	Functional									
7	Functional									
8	Functional									
9	Functional									
10	Functional									
11	Functional									
12	Full Duration									

INS/EMERGENCY_TESTING_SHEET/V3



Red Arrow Electrical Ltd
Cortonwood Drive, Brampton,
Barnsley, S73 0UF

T: 0114 279 8999
sales@redarrowelectrical.co.uk

redarrowelectrical.co.uk